

# Alira X

## Reverse Cycle Split System

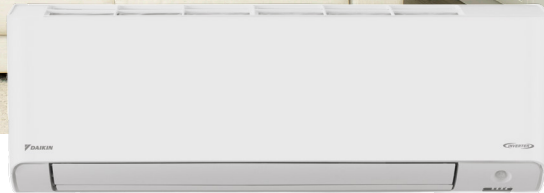

ENERGY RATING	
6.0 ★	HOT climate 4.0 ★
5.5 ★	AVERAGE climate 3.5 ★
5.5 ★	COLD climate 3.0 ★

25 Class Model

## A REFLECTION OF QUALITY

Alira X is a step ahead of the rest, delivering a perfect fusion of whisper quiet comfort, industry-leading energy efficiency and indoor air quality technology.

- 
**Perfect fusion**  
 R32 Alira X is a perfect blend of progressive design aesthetic, superior energy performance & indoor air quality technology.
- 
**Advanced purification**  
 Fitted with three layers of filtration; prefilter for large particulates, enzyme blue deodorising filter for odours and Daikin's Streamer Technology for powerful oxidative decomposition of pollutants.
- 
**Mould-proof operation**  
 Activates after cooling or dry operation to prevent the build up of mould and odour.\*
- 
**Built-in Wi-Fi**  
 Connection to Daikin's Mobile Controller smartphone interface is now included.
- 
**Intelligent comfort**  
 The 2-Area Intelligent Eye\*\* helps prevent cold draughts and enables energy saving operations when the room is unoccupied.
- 
**Coanda airflow**  
 Discharge louvres are designed to stream air upwards along the ceiling for rapid cooling and uniform temperature distribution.

## Technology

**IMPROVED ODM MOTOR**  
 Improved compact 14 pole DC outer diameter rotor motor encased in rubber vibration dampeners delivers higher torque more efficiently than before while ensuring whisper quiet operations.

**REDESIGNED DUAL LOUVRES**  
 Large dual louvres with aerodynamic end vanes help reduce turbulence for draught free comfort with longer throw distances of up to 10m (50-71 Class).

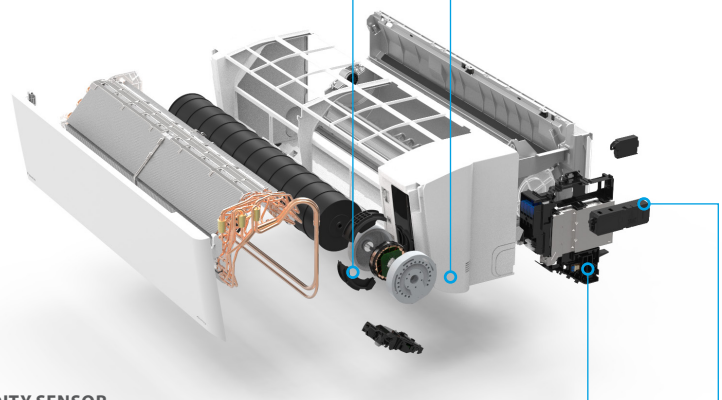

**HUMIDITY SENSOR**  
 Monitors humidity to accurately control supply air temperature for comfortable and effective dehumidification of the room during Program Dry Function operation.

**STREAMER TECHNOLOGY**  
 Discharges high speed electrons generating powerful oxidative decomposition that has been proven to eliminate more than 99.6%<sup>^</sup> of pollen in 2 hours, 99.9%<sup>^^</sup> of mould in 24 hours and 99.61%<sup>^</sup> of allergens in 24 hours.



\* Mould-proof operation function can be toggled (On/Off) via the wireless controller

\*\* 2-Area Intelligent Eye only applicable to 20-46 Class Models

<sup>^</sup>Verified at Wakayama Medical University with the following test condition: Irradiated allergens with Streamer & checked decomposition of allergen proteins by either the ELISA method, electrophoresis or electron microscopy.

<sup>^^</sup>Verified at Japan Food Research Laboratories using antibacterial test/mould elimination test (test number: 204041635-001).

# SPECIFICATIONS



Indoor Unit		FTXM20YVMA	FTXM25YVMA	FTXM35YVMA	FTXM46WVMA	FTXM50WVMA	FTXM60WVMA	FTXM71WVMA
Outdoor Unit		RXM20YVMA	RXM25YVMA	RXM35YVMA	RXM46WVMA	RXM50WVMA	RXM60WVMA	RXM71WVMA
Rated Capacity	Cool (kW)	2.2	2.5	3.5	4.6	5.0	6.0	7.1
	Heat (kW)	2.7	3.2	3.7	4.7	6.0	7.2	8.0
Capacity Range	Cool (kW)	1.0-2.8	1.0-3.7	1.0-4.2	0.9-5.5	1.1-6.7	1.1-7.5	2.0-8.9
	Heat (kW)	1.0-4.4	1.0-5.4	1.0-5.5	1.0-6.7	1.0-8.0	1.0-9.8	2.0-10.8
Indoor Airflow Rate (H)	Cool (l/s)	203	215	225	253	342	395	410
	Heat (l/s)	198	213	225	250	342	395	410
Indoor Fan Speeds		5 steps, quiet and automatic						
Star Rating (Hot/Avg/Cold) ZERL (Residential)	Cool	6/5/5	6/5.5/5.5	5/4.5/5	4.5/4/4.5	5.5/5/5	4.5/4.5/5	4/3/3.5
	Heat	3.5/3.5/3	4/3.5/3	3.5/3.5/3	4/3.5/3	4/3.5/3	4/3/2.5	3.5/3/2.5
Front Panel Colour		White						
Power Supply		1 phase, 220-240V, 50Hz						
Power Input (Rated)	Cool (kW)	0.42	0.47	0.80	1.17	1.13	1.48	2.00
	Heat (kW)	0.50	0.64	0.76	1.04	1.23	1.61	1.96
E.E.R./C.O.P	Cool/Heat	5.29/5.40	5.38/5.00	4.38/4.89	3.95/4.52	4.42/4.88	4.05/4.47	3.55/4.08
T.C.S.P.F (Residential)	Hot/Avg/Cold	7.80/6.85/6.99	7.99/7.13/7.28	6.96/6.48/6.77	6.09/5.71/6.06	7.00/6.56/6.99	6.49/6.11/6.55	5.50/4.87/5.07
H.S.P.F (Residential)	Hot/Avg/Cold	5.34/5.13/4.76	5.50/5.12/4.71	5.44/5.02/4.50	5.61/5.03/4.52	5.84/5.25/4.60	5.50/4.90/4.26	5.10/4.54/4.00
A.E.E.R./A.C.O.P	Cool/Heat	5.20/5.33	5.30/4.95	4.34/4.84	3.94/4.50	4.41/4.86	4.04/4.46	3.49/4.02
Dimensions (HxWxD)	Indoor (mm)	299x838x275			299x920x275	299x1100x275		
	Outdoor (mm)	550x675x284			695x930x350			
Weight	Indoor (kg)	12	12	12	13	15	15	15
	Outdoor (kg)	28	30	30	51	54	54	60
Compressor Type		Hermetically Sealed Swing Type						
Refrigerant Type		R32						
Max Pipe Length	(m)	20	20	20	30	30	30	30
Max Level Difference	(m)	15	15	15	20	20	20	20
Pipe Sizes	Liquid (mm)	6.4	6.4	6.4	6.4	6.4	6.4	6.4
	Gas (mm)	9.5	9.5	9.5	12.7	12.7	12.7	15.9
Outdoor Operating Range	Cool (°CDB)	-10 to 46						
	Heat (°CWB)	-15 to 18						
Indoor Sound Level (H/SL)	Cool (dBA)	39/19	41/19	42/19	43/26	45/28	48/29	49/30
	Heat (dBA)	39/20	40/20	42/20	43/26	45/28	48/29	49/30
Outdoor Sound Level (H/SL)	Cool (dBA)	46/43	47/43	49/44	47/44	47/44	49/45	53/49
	Heat (dBA)	47/44	48/44	49/45	48/45	48/45	52/45	54/49
Outdoor EPA Sound Power Level (H)	Cool (dBA)	58	59	61	59	59	61	65
	Heat (dBA)	59	60	61	60	60	64	66

ZERL (Residential) refers to 'Zoned Energy Rating Label' residential star rating as outlined in the GEMS 2019 Determination.

## Notes:

- The Rated Capacity, Power Input and Running Current are determined under conditions T1 (cooling) or H1 (heating) of AS/NZS 3823.1.1  
Cooling: Indoor temp: 27°CDB/19°CWB, Outdoor temp: 35°CDB/24°CWB  
Heating: Indoor temp: 20°CDB/15°CWB, Outdoor temp: 7°CDB/6°CWB
- The cooling (or heating) output capacity will be reduced below the rated value as the outdoor temperature approaches the maximum (or minimum) outdoor temperature operating range limit.
- The specifications, designs & information in this flyer are subject to change without notice. Unit colours shown are as close as possible to actual unit colours. Colours depicted in this flyer may vary slightly.

## CONTACT



Daikin Australia Pty Limited ABN 62 000 172 967

For all Sales enquiries, email: [sales@daikin.com.au](mailto:sales@daikin.com.au)

For Customer Service or Technical Support, call: 1300 368 300

Want to learn more about our product range?

Subscribe to our YouTube Channel or go to [daikin.com.au](http://daikin.com.au)

